

Deka[®]

SOLAR

PHOTOVOLTAIC BATTERIES

Monoblock Flooded System

Installation and Operation Manual



TABLE OF CONTENTS

Safety Precautions

Protective Equipment	1
Procedures	1
Hazardous Elements.....	1
First Aid for Acid Splash	2

Battery Location

Space	2
Floor Preparation	2
Battery Racking System	2
Ventilation	2
Environment	2
Distance from Operating Equipment.....	2

Safety Equipment

Fire Suppression.....	2
Signage.....	3
Eye Wash Facilities.....	3

Battery Operation

Storage	3
Temperature	3
Depth of Discharge (DoD)	3
Charging	3
Maintenance	3

Battery Installation

Receiving a Battery.....	3
Lifting Batteries.....	4
Installing Batteries.....	4
Charging Safety	4
Connecting/Disconnecting Charger	4

Battery Operation

Discharge Voltage Curve	5
Charge Current	5
Calculating Recharge Time.....	5
Specific Gravity Readings.....	5
Placing Battery into Service	6

Battery Maintenance

Neutralizing Acid and Electrolyte	6
Adding Water/Adjust Electrolyte Levels	6
Performing a Test Discharge	7

Troubleshooting

APPENDIX A

Battery Maintenance Report	9-10
----------------------------------	------

APPENDIX B

Discharge Chart	11
-----------------------	----

Glossary

12-13

Only trained and authorized personnel should install, repair or charge batteries.

When used properly, a lead-acid renewable energy battery is a safe, dependable source of electrical power. However, if proper care and safety precautions aren't exercised when handling a battery, it can be an extremely dangerous piece of equipment.

There are four hazardous elements in a lead-acid battery: sulfuric acid, explosive gases, electricity, and weight.

PROTECTIVE EQUIPMENT

Per IEEE 450, the following protective equipment shall be worn by personnel who perform battery maintenance work or made available to such personnel:

- a) Goggle and face shields
- b) Acid-resistant gloves
- c) Protective aprons
- d) Portable or stationary water facilities for rinsing eyes and skin in case of contact with electrolyte.
- e) Bicarbonate of soda solution mixed 100 grams bicarbonate soda to 1 liter of water, to neutralize acid spillage.

Note: The removal and /or neutralization of an acid spill may result in production of hazardous waste. The user should comply with appropriate government regulations concerning disposal of such hazardous waste.

- f) Class C fire extinguisher.
- g) Adequately insulated tools
- h) Barrier to prevent the spread of acid spills are extremely important when moving cells such as during installation or removal activities. See IEEE 1578 for information on barriers.

PROCEDURES

The following safety procedures should be followed during installation: **(Always wear safety glasses or face shield when working on or near batteries.)**

1. These batteries contain sulfuric acid which can cause severe burns. Sulfuric acid is harmful to the skin and eyes. Flush affected area with water immediately and consult a physician if splashed in the eyes. Consult MSDS for additional precautions and first aid measures.
2. **Prohibit smoking and open flames, and avoid arcing in the immediate vicinity of the battery.**
3. Do not wear metallic objects, such as jewelry, while working on batteries. Do not store un-insulated tools in pockets or tool belt while working in vicinity of battery.
4. Keep the top of the battery dry and clear of tools and other foreign objects.
5. Provide adequate ventilation per IEEE standards and / or local codes and follow recommended charging voltages.
6. Extinguishing media: Class ABC extinguisher.
Note: CO₂ may be used but not directly on the cells due to thermal shock and potential cracking of cases.
7. Inspect all flooring and lifting equipment for functional adequacy.

8. Adequately secure battery racks to the floor.
9. Connect support structures to ground system in accordance with applicable codes.
10. The below IEEE Standards contain additional information. Other standards may be relevant to your specific application.

IEEE 450 – Recommended Practice for Maintenance, Testing, of Vented Lead-Acid Batteries for Stationary Applications

IEEE 937 – Recommended Practice for Installation & Maintenance of Lead-Acid Batteries for Photovoltaic (PV) Systems

IEEE 1013 – Recommended Practice for Sizing Lead-Acid Batteries for Stand-Alone Photovoltaic (PV) Systems

IEEE 1526 – Recommended Practice for Testing the Performance of Stand-Alone Photovoltaic Systems

IEEE 1578 – IEEE Recommended Practice for Stationary Battery Electrolyte Spill Containment and Management

IEEE 1660 – Guide for Application and Management of Stationary Batteries Used in Cycling Service

HAZARDOUS ELEMENTS

Sulfuric Acid: The electrolyte in a lead-acid storage battery is a diluted solution of sulfuric acid and water. Although the acid content in the solution is only about 37%, it is still a strong corrosive agent and can burn skin and eyes and create holes in many types of fabric. **(See Protective Equipment.)**

Explosive Gases: When a lead-acid battery is being charged, it produces an explosive mixture of hydrogen and oxygen gases. Make sure that all vent caps are unclogged and securely attached so that any gas is safely vented from the battery. Never smoke, use an open flame or create an arc or sparks on or near a battery without first eliminating explosive gases from the cells you're working on.

Electricity: An electric shock hazard exists for persons who come in contact with live parts of batteries when the voltage is over 50 volts. The higher the voltage, the greater the electric shock hazard. In addition, metallic objects coming in contact with exposed cell connectors will cause a short and can become very hot. Even shorts involving a single cell can become hot enough to cause severe burns.

Weight: These batteries are of significant weight. Serious injury can occur if batteries are not handled carefully during installation, removal or transport. Use proper lifting equipment and techniques at all times.

FIRST AID FOR ACID SPLASH

Eyes: Flush immediately with gently running water for at least 15 minutes. Seek immediate medical attention. For contact lens wearers, remove the lens before the eyes are flushed. A buffering or neutralizing agent shouldn't be used in the eyes without the approval of medical or safety personnel.

Skin: Wash affected area under running water and apply a chemical burn treatment. Severe burns require immediate medical attention.

Clothing: If large areas of clothing have been splashed or soaked with sulfuric acid, the clothing must be removed and the acid must be treated with non-corrosive water based neutralizing agent (ex: baking soda / water solution), that is user safe and environmentally compliant. After treatment rinse with running water. If clothing is treated immediately, chances of damage to the material are lessened. Acid-resistant boots should always be checked before wearing to be sure that there are no traces of acid inside.

BATTERY LOCATION

When planning a battery system the following requirements should be considered:

- ___ **Space**
- ___ **Floor Preparation**
- ___ **Battery Racking System**
- ___ **Ventilation**
- ___ **Environment**
- ___ **Distance from Operating Equipment**
- ___ **Safety Equipment**

Space

It is recommended that aisle space be provided in front of all battery racks be a minimum of 36.0" (915mm). The design should meet all applicable local, state and federal codes and regulations.

Floor Preparation

It is recommended to consult with a structural engineer to determine if the existing floor will withstand the weight of the battery and the battery racking system. The floors in which the battery will be located should have an acid-resistant coating and be sloped toward a sump. Any battery spills should be neutralized with non-corrosive, water based neutralizing chemical (ex: baking soda / water solution) that is user safe and environmentally compliant. The area should always be washed with clean water to remove any acid neutralizing chemical residue.

Battery Racking System

The battery should not be installed directly on a floor. There should be some type of barrier/racking between the floor and the batteries. This barrier/racking should be sufficient to handle the weight of the battery. The battery racking system must be suitably insulated to prevent sparking and eliminate any grounding paths.

Adequate space and accessibility for taking individual cell voltage, hydrometer readings and adding water should be considered. If installed in an earthquake seismic zone, battery racking system must be of sufficient strength and anchoring. Battery rack design should be reviewed by structural engineer.

Ventilation

It is the responsibility of the installer to provide detailed methods or engineering design required by Federal, State and local regulations to maintain safe levels of hydrogen in battery rooms / enclosures.

The rate of hydrogen evolution is highest when the battery is on charge. Explosive mixtures of hydrogen in air are present when the hydrogen concentration is greater than or equal to 4% by volume. To provide a margin of safety, battery room / enclosure must be ventilated to limit the accumulation of hydrogen gas under all anticipated conditions. This margin of safety is regulated by Federal, State and Local codes and is typically limited to 1 to 2% by volume of the battery room / enclosure. Consult all applicable codes to determine specific margin of safety. Hydrogen gas calculations can be determined by using proper formulas.

Hydrogen gas is lighter than air and will accumulate, creating pockets of gas in the ceiling. The ventilation system should be designed to account for and eliminate this situation. Ventilation system must be designed to vent to the outside atmosphere by either natural or mechanical means in order to eliminate the hydrogen from the battery room / enclosure.

Environment

Batteries should be located in a clean, cool and dry place and isolated from outside elements. The selected area should be free of any water, oil and dirt from accumulating on the batteries.

Distance from Operating Equipment

Battery systems are sized based on a specific load (Amps or Watts) for a specific run time to a specific end voltage. Battery performance is based on these values, as measured at the battery terminals.

For proper operation of the battery system the following should be considered:

- Distance between battery system and operating systems should be kept at the shortest distant possible
- Cables are to be of proper gauge to handle system loads and minimize voltage drops.
- All cable lengths from battery system to operating system should be of the same wire gauge and length.

The above is to ensure the battery cable used will be able to carry the charge / discharge current & minimize the voltage drop between equipment.

Electrical equipment should not be installed above the batteries, because of the corrosive fumes being released from the battery(s).

SAFETY EQUIPMENT

Fire Suppression

Hand-operated fire extinguishes should be available in the battery room even if the areas are equipped with automatic sprinkler systems. For information on extinguisher class, size and mounting locations, consult local fire authorities or your insurance carrier.

Signage

Because of the explosive gas mixtures generated while charging batteries, anything that could ignite the gas, such as sparks, open flames, an electrical arc, smoking, etc., must be prohibited in the charging areas. To serve as a prominent reminder, “NO SMOKING” signs should be posted in all battery room areas.

Eye Wash Facilities

Emergency eye wash and acid neutralization facilities should be located in the immediate work area for easy access. The three most popular types of eye wash and acid neutralizing equipment are the chemical burn station, deluge shower, and eye wash fountain.

Consult all applicable Local, State, and Federal codes to ensure compliance.

BATTERY OPERATION

There are several factors that affect the operation of the battery concerning its ability to deliver capacity and life expectancy.

Storage

IEEE recommends:

Batteries should be stored indoors in a clean, cool, dry, level, well-ventilated area away from direct sunlight. Typical storage temperature range is 32°F (0°C) to 86°F (30°C).

Storage time should be limited to 3 – 6 months. It is recommended the battery be fully charged and the electrolyte is at the proper level, prior to storing. If the battery must be stored for several months, a freshening charge should be given whenever the voltage falls below 12.40V (12V)/6.20V (6V). If the average storage temperature is below 77°F (25°C), check the voltage at least once every two months. If the temperature is above 77°F (25°C), check it every month.

Batteries should be covered with a non-conductive material to protect them from dirt, moisture, etc. A flat sheet of rigid plastic or plywood is not recommended. Do not drape flexible plastic sheeting over batteries because it may trap explosive gases underneath.

Note: If batteries are to be stored for more than 6 months, consult with nearest authorized East Penn representative.

Temperature

Many chemical reactions are effected by temperature, and this is true of the reaction that occurs in a storage battery.

The chemical reaction of a lead-acid battery is slowed down by a lowering of the electrolyte temperature that results in less capacity. A battery that will deliver 100% of rated capacity at 77° F will only deliver 65% of rated capacity at 32°F.

Excessive heat will increase the natural corrosion factors of a lead acid battery. This increase corrosion of the positive plates contributes greatly to reducing the overall life of the battery.

Depth of Discharge (DoD)

Depth of discharge is a function of design. The deeper the discharge per cycle the shorter the life of the battery. A cycle is a discharge and its subsequent recharge regardless of depth of discharge.

System should be designed for shallow discharges. The result of shallower discharges is typically a larger capacity battery at prolonged battery life.

Charging

Majority of battery issues can be traced to improper charging.

Improper charging settings will lead to overcharging or undercharging condition. Each condition will result in reduced capacity and/ or battery life.

To ensure proper charging the inverter / charge controller should be set to the recommended battery voltage settings. If battery is located in an uncontrolled temperature environment, temperature compensation should be used.

Maintenance

IEEE 450 suggests batteries be checked on a monthly, quarterly and yearly basis. Each time period requires different checks. Maintenance log should be initiated at time of installation. Typical checks consists of voltage & specific gravity readings and well as visual inspections. Periodic verification of proper gravity readings and electrolyte levels will ensure battery being fully charged and operating properly. If any conditions are found that are out of specifications, corrections should be made.

A good battery maintenance program is necessary to protect life expectancy and capacity of the battery.

BATTERY INSTALLATION

Receiving a Battery

After receiving a battery, examine the crate and pallet for signs of damage. If you see any wet spots, the battery may have been tipped or damaged during transit. Be careful when handling a crate or packing material that's contaminated with spilled electrolyte. Chemical burns can result if skin or clothing comes in contact with the spillage.

Every cell should be inspected to be sure that the electrolyte level is above the moss shield. If the electrolyte level is slightly below the moss shield in any cell, it can be raised by transferring a small amount of acid from higher level cells within the battery by using a syringe or hydrometer. Do not fill with water to bring levels to above the moss shield.

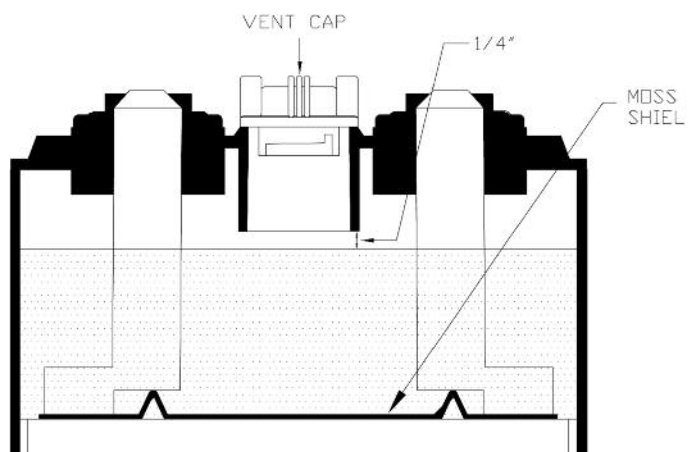

If a large amount of liquid is required to raise the level, the battery may be damaged. Inspect the packing material under the tray for signs of leakage. All damaged components should be inspected by your East Penn agent or representative.

Receiving a Battery *cont.*

Call your East Penn representative immediately. In the meantime, keep the damaged cell's vent cap tightly in place and protect the floor from acid leakage. **Do not attempt to discharge or charge the battery.**

Lifting Batteries

Always use the proper lifting equipment to reduce the risk of tray damage, shorting and possible injury.

Chain hoists used to handle batteries should be equipped with a non-metallic container or bucket to prevent the chains from dangling and possibly causing a short by coming in contact with exposed intercell connectors on the battery top. If no protection is available, cover the battery with a non-conducting insulating material such as plywood or heavy plastic.

Installing Batteries

There should be some type of barrier/racking between the floor and the batteries. Battery rack(s) should be installed per rack manufacturer's instructions. Battery rack should be securely anchored to the floor. Floor anchoring and its design are the responsibility of the owner and should meet all local, state and/or federal codes.

Caution should be observed when installing battery on racking system. Consult battery layout to ensure batteries are installed in the correct polarity order. Batteries are shipped assembled, charged and filled with electrolyte to just below the bottom of the vent well. If the electrolyte level is above the low end of the vent well after the battery has been on a long open circuit stand, care must be taken to avoid flooding during the initial charge. Electrolyte may be removed to the bottom of the vent well to prevent overflowing.

Battery terminals should be cleaned of all oils, greases or corrosion prior to installing cables. The surface of the battery terminals may be cleaned using a stiff-bristle nonmetallic brush/pad until a clean bright surface is accomplished.

Ensure all inter-battery connections and battery cables are properly connected and polarity is correct. All inter-battery cables should be of the same length and wire gauge. Cables should be at minimum length to reduce voltage drop. Use a voltmeter to confirm correct polarity. Lug bolt hole should be 5/16" in dia. Hardware supplied with battery should be used. All battery connections should be torque to 100-120 in lb.

All Parallel Connections should be of the same length and wire gauge and be terminated at a common bus. This will ensure all parallel battery strings are being discharged & charged at the same voltage and current.

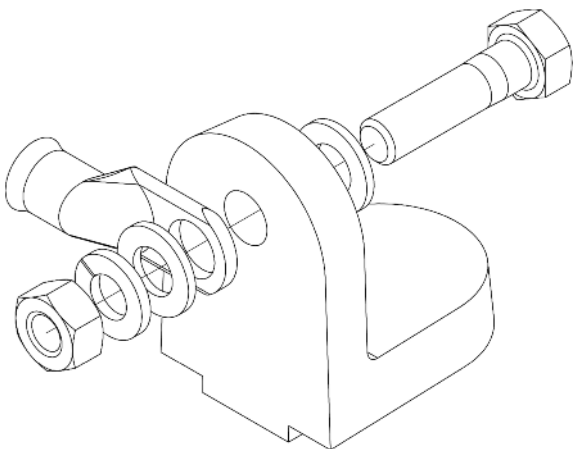

Charging Safety

There are several important safety precautions that should be taken when charging a battery:

- **Do not use open flames when checking the electrolyte levels in storage batteries.**
- **Keep all open flames, sparks and matches away from the charging area. DO NOT SMOKE around the charging area.**
- **Only properly trained personnel understanding all safety measures, charging parameters and required maintenance prior to charging should charge batteries.**
- **Follow charger manufacturers recommendations for charger connection / disconnection sequence.**
- **All mechanical connections on the battery and charger should be tight. Torque all connections to specification. Loose connections can overheat and cause arcing that could cause a gassing cell to explode, or cables to become hot to the touch.**
- **Vent plugs should be kept firmly in place at all times to minimize electrolyte spray when the battery gasses.**

Connecting/Disconnecting Charger

Always turn the charger OFF before connecting or disconnecting a battery. Live leads can cause arcing and sparking, which could cause an explosion if battery gases are present. In addition, the contact surfaces of the plugs or connectors will become pitted over time.

BATTERY OPERATION

There are several factors that affect the operation of the battery concerning its ability to deliver capacity and life expectancy. Many chemical reactions are affected by temperature, and this is true of the reaction that occurs in a storage battery. The chemical reaction of a lead-acid battery is slowed down by a lowering of the electrolyte temperature that result in less capacity. A battery that will deliver 100% of rated capacity at 77° F (25°C) will only deliver 65% of rated capacity at 32° F (0°C).

Discharge Voltage Curve

To estimate battery voltage during a constant current discharge at various DoD (Depth of Discharge) consult chart Discharge Voltage Curve in Appendix B.

NOTE: Battery voltage can vary depending on temperature, age and condition of battery.

CHARGING PARAMETERS

Bulk Charge:
Current limited to 30% of C20 or 6 times I20.

Absorption Charge:
13.98V to 14.28V

Float Charge:
13.44V to 13.56V

Equalize:
14.64V to 14.82V

For 6V battery divide voltage values by 2.

To determine the correct system voltage, multiple the number of cells connected in series by the above values.

The best way to determine if the battery needs an equalizing charge is to check the specific gravity readings for each cell. If there is more than 0.020 specific gravity unit variation between any two cells, the battery should be equalized.

For installations in an uncontrolled temperature environment it is highly recommended the Charge Controller / Inverter be used that has voltage temperature compensation. Charging without voltage temperature compensation can result in both under and overcharging of the battery system resulting in reduced battery life and may be a determining factor with warranty claims.

Charge Current

To properly determine the amount of charge current required, the following variables are to be considered:

- DoD (Depth of Discharge)
- Temperature
- Size & efficiency of the charger
- Age & condition of battery(ies)

Maximum charge current should be limited to 30% of the C20 Ah rate for the battery(ies) being used in the system.

**Example: 8L16 C20 rate – 370Ah
Max. recharge rate: 370Ah x 0.3 = 111A**

Calculating Recharge Time

The following can be used as a guideline for determining recharge times:

85% to 90% SOC (State of Charge)

Time (hrs) = (Ahr x 1.2) / I_c

Note: I_c should be < 30% of C20

Ahr = Amp Hours removed during discharge.

I_c = Maximum current available to battery from charger.

C20 = C20 rate in Ah

East Penn Mfg recommends returning 120% of Ah removed to insure 100% SOC (State of Charge).

Specific Gravity Readings

The following applies when using a manual hydrometer. To take a specific gravity reading, remove the cell's vent cap, place the rubber hydrometer nozzle into the vent opening and draw enough electrolyte into the barrel to permit the float to rise freely. Hold the hydrometer at eye level as shown below.

HOLD HYDROMETER VERTICAL



TAKE READING AT EYE LEVEL

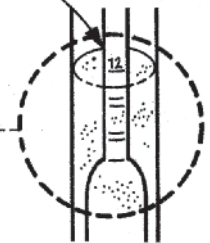

The correct hydrometer reading corresponds to an imaginary line drawn across the side of the barrel at the lowest level of the electrolyte. If the hydrometer has to be removed from the vent hole, pinch the nozzle tightly or place a gloved finger against the opening to prevent dripping.

Specific gravity measurements are based on a cell temperature of 77°F (25°C). In order to obtain an accurate specific gravity measurement, the hydrometer reading must be adjusted based on the temperature of the electrolyte. A good rule of thumb for temperature correction is to add 4 points of specific gravity (.004) for each 10°F above 77°F and to subtract 4 points for each 10°F degrees under 77° F (25°C).

To take the temperature reading, insert a thermometer into the electrolyte of the pilot cell. If the thermometer doesn't have specific gravity/temperature corrections marked on it, refer to the above paragraph.

Battery specific gravity and open circuit voltage can be used to determine the SOC (State of Charge) of a battery.

The below chart details OCV & Specific Gravity to SOC:

% SOC	Specific Gravity	OCV Voltage
100	1.265	12.66
75	1.225	12.44
50	1.190	12.25
25	1.155	12.06
0	1.120	11.87

For 6V battery divide voltage values by 2.

Note: True OCV of a battery can only be determined after the battery has been removed from the load (charge or discharge) for 24 hours.

Placing Battery into Service

Battery voltage, specific gravities of each individual cell as well as temperature of pilot cell should be taken and recorded prior to battery being placed on charge. See Battery Maintenance Report Appendix A

Proper charging is essential for maximum battery life. A temperature compensated voltage regulated charger is recommended to be used in renewable energy applications.

When a discharged battery is initially placed on charge, it draws a current equal or close to the charger's maximum output. As the battery's voltage rises, the charger output should adjust to the changing voltage to assure a safe, efficient charging rate during all stages of the charge.

A freshening charge at the absorption charge rate should be given to a new battery before putting it into service. The battery should be cool; less than 90°F (32°C), when it's installed. The battery should remain in equalize until the specific gravity shows no change for a three-hour period with readings taken hourly or a max. of 12 hrs.

Proper maintenance is essential to obtain long life and maximum efficiency from any renewable energy battery. Carefully following a scheduled maintenance routine will help increase battery performance and prolong service life. Maintain an accurate records system of battery cycles and maintenance/repair work for each battery. A records system is particularly important for operations that use a large number of batteries.

If you don't already have one, these procedures should help you create a reliable records system:

1. Assign a code/identification number to each battery / cell.
2. Record the specific gravity, voltage and temperature of each battery when the battery is first received and equalized, and **before and after each charge.**
3. At least once each month, measure and compare the specific gravity of all the cells. The readings should be uniform from cell to cell. If the specific gravity readings fall 20 points (0.20) below the nominal specific gravity reading of 1.265, the electrolyte levels should be checked and brought up to a uniform level before checking for a second time. If, at any time, the readings are 20 points (.020) greater than the nominal specific gravity readings of 1.265, or the range of the on-charge cell voltage readings is more than 0.15 volts, the battery could be showing signs of cell failure. Contact your authorized East Penn Mfg Representative.
4. Remember to accurately record the number of cycles, specific gravity, temperature and voltage readings; and all maintenance and repair information for every battery. Maintenance Report Appendix A is an example of a basic record-keeping form.

BATTERY MAINTENANCE

Batteries should be inspected periodically to avoid damage resulting from previously undetected problems or improper maintenance and operational procedures.

Look for:

- Corrosion on the battery, terminals or intercell connectors.
- Leaks or damage to the tray.
- Damaged cable leads, terminals or connections.
- Damaged, clogged or missing vent caps.

Repair or replace any damaged parts and thoroughly clean the battery. In case of serious damage or for major repairs, contact nearest authorized East Penn representative.

Before taking any specific gravity or voltmeter readings, the battery should be fully charged. Take specific gravity and voltage readings for each cell and record the readings on your battery inspection form. Use the battery's positive terminal cell as cell #1 and follow the intercell connectors to the last cell (the battery's negative terminal cell). Look for any unusual readings that might indicate a problem battery.

Neutralizing Acid and Electrolyte

For cleaning batteries, non-corrosive, water based battery cleaning products are all that should be used. For user safety and environmental regulatory compliance, the cleaning liquid should contain no hazardous chemical ingredients. Even some products labeled "Battery Cleaner" must be avoided because of hazardous ingredients and damage to batteries and related equipment.

Acid spills are common in battery rooms. When acid spills occur it is critical to minimize:

1. Health and safety risk to personnel and the environment.
2. Damage to batteries, equipment, and surrounding surfaces.
3. Time to neutralize, absorb, and clean-up.
4. Disposal costs of waste materials.
5. Regulatory compliance risks and fines.

Neutralizing acid absorbers and spill kits have the performance attributes required when dealing with acid spills. The ph neutral dry and non-hazardous waste is easy to sweep-up and dispose as non-hazardous waste.

Adding Water/Adjust Electrolyte Levels

Batteries normally lose a certain amount of water due to evaporation and electrolysis during charging. The electrolyte level should be maintained at a ¼" below the bottom of the vent well opening of the cover. It is important not to allow the electrolyte level in any cell to drop below the top of the moss guard, since low levels can damage the plates and shorten life.

It is equally important to avoid overfilling the cells, as electrolyte will be forced out of the vent caps during charging onto the top of the battery, causing tray corrosion and reducing battery capacity.

Only distilled or de-ionized water should be used to water cells because certain impurities and chemicals found in tap water can be harmful to batteries. Warranty may be affected if water other than distilled or de-ionized is used.

Distilled or de-ionized water should only be added to batteries while the batteries are on charge and gassing or as soon after recharge as possible. This will prevent overfilling because the electrolyte is at its maximum level during this time. To prevent low electrolyte levels, frequent checks should be made and water should be added when necessary.

How a watering schedule is determined depends on the type of battery, frequency of charge, temperature of the battery, and age and condition of the battery. Excessive water loss may be caused by shorted or weakened cells, excessive charging rates, or the charger not shutting off automatically. Cells that continually lose excessive amounts of water should be checked for possible internal damage.

Performing a Test Discharge

To determine if a battery can deliver its rated capacity, a test discharge, or capacity test, can be performed. This test helps determine the “health” of a battery and whether or not it should be replaced.

Only experienced battery technicians should be allowed to prepare a battery for discharge testing and to conduct the actual discharge test.

The test is conducted by discharging a fully charged battery at a specific rate until the battery voltage drops to a predetermined volts per cell, times the number of cells in the battery.

By noting the time elapsed between when the battery was put on discharge and when the final voltage was reached, you can determine whether the battery is delivering its rated capacity:

1. Give the battery an equalizing charge and adjust the specific gravity to the manufacturer’s specification, with the electrolyte level at the bottom of the vent well. Always temperature correct the gravity readings.
2. Start the test and record the starting time.
3. Record battery voltages during the first hour at 10 minutes, 30 minutes and then 60 minutes. After the first hour, take hourly readings until the first battery voltage reaches 1.80 volts per cell. From this point on, record the voltage of the batteries every 5 minutes.
4. Carefully monitor the voltage of the low batteries and as the voltage of each battery drops below the predetermined final voltage, record the time.
5. When the majority of the battery reach termination value, stop the test. Don’t let any battery go into reversal.
For example, if the test was run at the 360 minute rate was terminated after 336 minutes; the capacity percentage would be 93%
6. After termination of the test, immediately record the specific gravity of each cell. If all the cells have uniform specific gravity and the battery delivers 50% or more of its rated capacity, it can be returned to service. If the test indicates that less than 50% of the battery’s rated capacity is being delivered, the battery should be either repaired or replaced, depending upon its age and overall condition.

For more detailed information on capacity testing, contact East Penn Manufacturing Company or your local authorized East Penn Representative.

TROUBLESHOOTING

SYMPTOMS	POSSIBLE CAUSES		REMEDY	
Battery Overheats During Charge	1	Malfunctioning Charger Equipment	1	Repair or replace charger equipment
	2	Charge Controller / Inverter voltage settings out of specification	2	Adjust voltage settings per battery manufacturers recommendations
	3	Defective or weak cell(s)	3	Replace problem battery
	4	High resistance connection within battery	4	Check for hot wires, cells, intercell connections, charging cables. Repair or replace defective component(s)
	5	Low electrolyte level	5	Add water to moss cover when battery is in discharged state
Battery not able to supply power as when initially installed	1	Battery not fully charged	1	Charge battery until electrolyte specific gravities are within specification
	2	Weak, leaking or defective cell(s) in battery	2	Replace problem cell(s)
	3	Ground or shorts in battery	3	Remove grounds or shorts
	4	Battery used beyond its useful life	4	Replace battery with equal or higher capacity battery
	5	PV Electrical system problem	5	Troubleshoot PV electrical system
	6	Battery undercharged for long period of time and now sulfated	6	Verify charge controller / Inverter charge settings are within recommendations. Recharge battery until battery is at full state of charge. Perform discharge test.
Battery charge voltage readings do not change during ambient temperature variations	1	Temperature compensation not present or not working	1	Verify temperature compensation is installed and working correctly
Low electrolyte	1	Electrolyte puddle on the floor Cracked or broken jar(s)	1	Replace cracked battery
	2	Cell missed when watered	2	More careful attention when watering
	3	Defective or weak cell(s)	3	Replace problem battery
	4	Frequent overcharge	4	See items 1 & 2 in "battery overheats during charge"
	5	Battery not regularly watered	5	Water battery regularly
Unequal Cell voltages	1	Grounds in battery	1	Clean battery
	2	Battery used beyond its useful life	2	Replace battery with equal or higher capacity battery
	3	Weak, leaking or defective cell(s) in battery	3	Replace problem battery

APPENDIX B

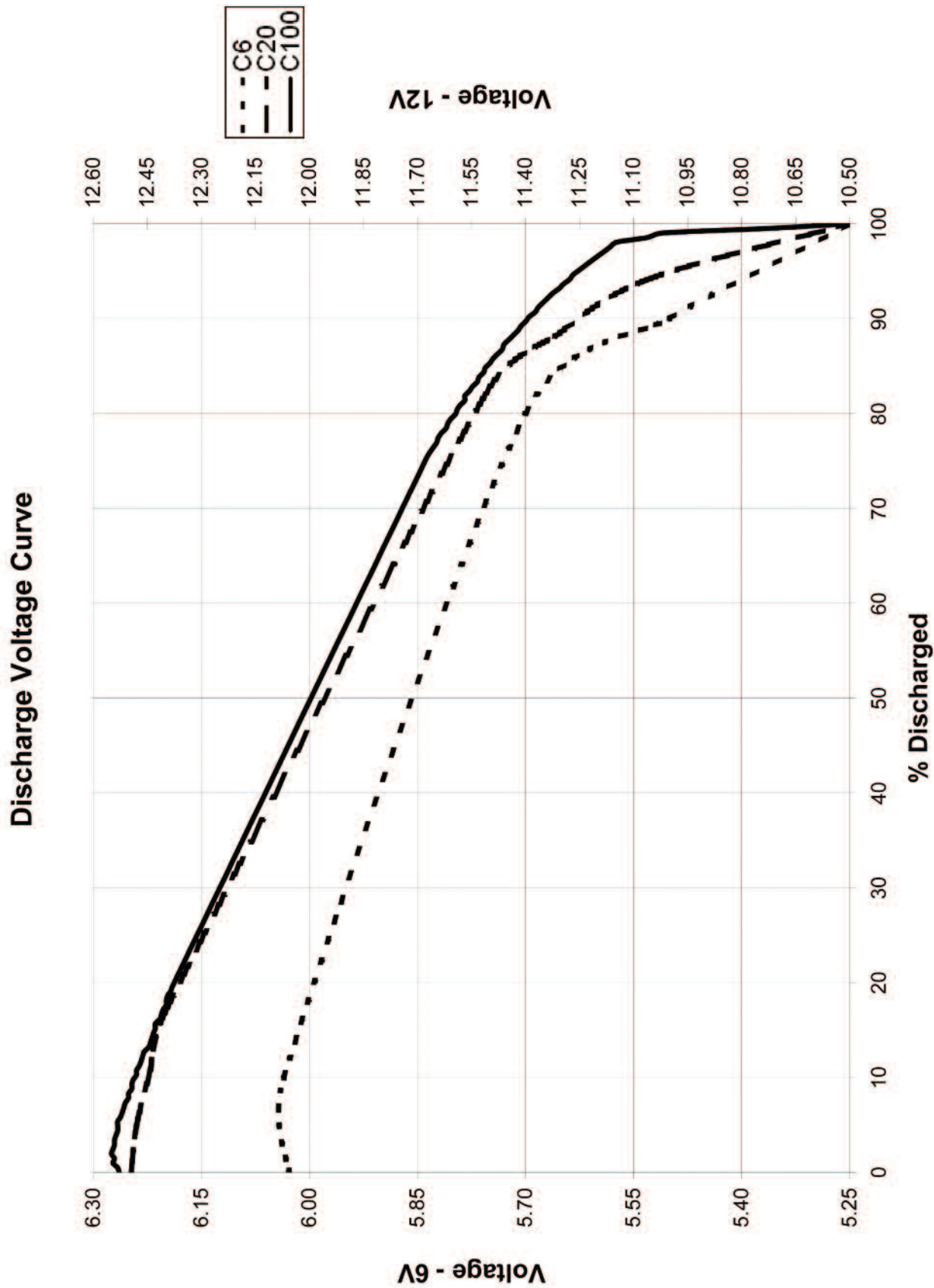

GLOSSARY

Absorption (Regulation) Charge – The charger will attempt to hold its output voltage constant while the battery continues to absorb charge (draw charging current) from the charger. The rate at which the battery continues to absorb charge in this mode gradually slows down. The amplitude of the charger current is gradually decreasing. The charge current is falling and the battery voltage is flat (constant).

Acid In the lead acid storage battery industry, “acid” implies “sulfuric acid”.

Ambient Temperature The temperature of the surrounding cooling medium, such as gas or liquid, which comes into contact with the heated parts of the apparatus, usually refers to room or air temp.

Ampacity Current carrying capacity in amperes.

Ampere (Amp) The practical unit of electric current that is equivalent to the steady state current produced by one volt applied across a resistance of one ohm. It is one tenth of an ampere.

Ampere-Hour A measure of the volume of electricity, being one ampere for one hour, or 3600 coulombs. It is used to express battery capacity, and is registered by an ampere hour meter, or is obtained by multiplying the current in amperes by the length of time that the current is maintained.

Ampere-Hour Capacity The number of ampere-hours which can be delivered under specified conditions as to temperature, rate of discharge, and final voltage.

Battery (Storage) A storage battery is a connected group of two or more storage cells (common usage permits this term to be applied to a single cell used independently). Batteries are sometimes referred to as “Accumulators” since electric energy is accumulated by chemical reaction.

Bulk Charge – Current is applied to the batteries at the maximum safe rate they will accept until voltage rises to near (80-90%) full charge level.

Capacity See *AMPERE HOUR CAPACITY*

Capacity Test A test wherein the battery is discharged at constant current at room temperature to a cutoff voltage of usually 1.70 volts/cell.

Cell (Storage) A storage (secondary) cell is an electrolytic cell for the generation of electric energy in which the cell after being discharged may be restored to a charged condition by an electric current flowing in a direction opposite to the flow of current when the cell discharges.

Charged The condition of a storage cell when at its maximum ability to deliver current. The positive plate contains a maximum of lead peroxide and a minimum of sulfate, while the negative plates contain a maximum of sponge lead and a minimum of sulfate, and the electrolyte will be at maximum specific gravity.

Charging The process of converting electrical energy to stored chemical energy. In the lead-acid system, charging converts Lead Sulfate (PbSO₄) in the plates to Lead Peroxide (PbO₂) (positive) or Lead (Pb) (negative plate).

Charging Rate The current expressed in amperes at which the battery is charged.

Circuit A system of electrical components through which an electric current is intended to flow. The continuous path of an electric current.

Constant-Current Charge A charge in which the current is maintained at a constant value. (For some types of lead-acid batteries this may involve two rates called a starting and a finishing rate.)

Constant Voltage Charge A charge in which the voltage at the terminals of the battery is held at a constant value.

Cut-Off Voltage See *FINAL VOLTAGE*

Cycle A discharge and its subsequent recharge.

Cycle Service A type of battery operation in which a battery is continuously subjected to successive cycles of charge and discharge, e.g., motive power service.

Deep Discharge Removal of up to 80% of the rated capacity of a cell or battery.

Direct Current (DC) A direct current is a unidirectional current in which the changes in value are either zero or so small that they may be neglected.

Discharge The conversion of the chemical energy of the battery into electrical energy.

Discharged The condition of a storage cell when as the result of delivering current, the plates are sulfated, the electrolyte is exhausted, and there is little or no potential difference between the terminals.

Discharge Rate Batteries discharged to meet any time rate between 3 hours and 8 hours are considered as having been normally discharged.

Efficiency The ratio of the output of the cell or battery to the input required to restore the initial state of charge under specified conditions of temperature, current rate and final voltage.

Electrolyte Any substance which disassociates into two or more ions when dissolved in water. Solution of electrolyte conduct electricity and are decomposed by it. In the battery industry the word “electrolyte” implies a dilute solution of sulfuric acid.

Equalizing Charge An extended charge which is given to a storage battery to insure the complete restoration of active materials in all the plates of all the cells.

Final Voltage The cut-off voltage of a battery; The prescribed voltage reached when the discharge is considered complete.

Float Charging Application of a recharge at a very low rate and accomplished by connection to a buss whose voltage is slightly higher than the open circuit voltage of the battery.

Full Charge Gravity The specific gravity of the electrolyte with the cells fully charged and properly leveled.

Gassing The evolution of gases from one or more of the electrodes during electrolysis.

Gravity Refers to specific gravity.

Hydrometer Device used to indicate density or specific gravity of electrolyte solutions.

Lead (Pb) Chemical element used in lead-acid batteries (with sulfuric acid and other materials).

Lead Sulphate (PbSO₄) A compound resulting from the chemical action of sulfuric acid on oxides of lead or lead metal itself.

GLOSSARY

Life Number of years of satisfactory float operation or number of charge-discharge cycles for motive power operation.

Loss of Charge The capacity loss occurring in a cell or battery standing on open circuit as a result of local action.

Lug Portion of grid used for support of the plate group, usually along top edge of grid, as "hanging lug." Also, tab on grid used for connection of plate to strap and other plates.

Millivolt (MV) One thousandth part of a volt.

Moss Dendritic crystals of lead (Pb) which sometimes grow at high-current density areas of negative plates, e.g. along edges, at feet, or a plate lugs. May cause a short circuit within cell.

Moss Shield Plastic or hard rubber perforate sheet which insulates the gaps between negative plates and the positive strap, and between positive plates and the negative strap.

Negative Terminal The terminal toward which current flows (as ordinarily conceived) in the external circuit from the positive terminal.

OHM A unit of electrical resistance.

Open Circuit The state of a battery when it is not connected to either a charging source or to a load circuit.

Open Circuit Voltage The voltage at its terminals when no appreciable current is flowing.

Pilot Cell A selected cell of a storage battery whose temperature, voltage, and specific gravity are assumed to indicate the condition of the entire battery.

Plate A pasted grid, either formed or unformed.

Polarity An electrical condition determining the direction in which current tends to flow. By common usage the discharge current is said to flow from the positive electrode through the external circuit.

Positive Plates Consists of the grid and the active material from which current flows to the external circuit when the battery is discharging.

Positive Terminal The terminal from which current flows (as ordinarily conceived) through the external circuit to the negative terminal when the cell discharges.

Post Terminal or other conductor which connects the plate group strap to the outside of the cell.

Rated Capacity The ampere hours of discharge that can be removed from a fully charged secondary cell or battery, at a specific constant discharge rate at a specified discharge temperature and at specified cut off voltage.

Self Discharge Loss of charge due to local action.

Short Circuit Current The current which flows when the two terminals of a cell or battery are inadvertently connected to each other.

Standing Loss The loss of charge by an idle cell or battery, resulting from local action.

State of Charge (SOC) The amount of electrochemical energy left in a cell or battery.

Stratification As applied to electrolyte it is layers of high gravity acid in the lower portions of a cell, where they are out of touch with the ordinary circulation of the electrolyte and thus of no use.

Sulfated A term used to describe any plate or cell whose active materials contain an appreciable amount of lead sulfate.

Sulfation The formation of lead sulfate on a plate or cell as a result of discharge, self-discharge, or pickling.

Sulfuric Acid (H₂SO₄) The principal acid compound of sulfur. Sulfuric acid of a high purity and in dilute form is the electrolyte of lead-acid storage cells.

Temperature Correction In storage cells, the specific gravity and charging voltage vary inversely with temperature, while the open circuit voltage varies directly (though slightly) with temperature.

Terminals The terminals of a battery are the points at which the external circuit is connected.

Tray Steel enclosure for motive power battery cells.

Vent An opening provided to permit the escape of gas from a cell or mold.

Vent Assembly A cell venting device consisting of a ceramic vent stone and filler funnel assembled on a threaded or a quarter turn bayonet base.

Vent Cap See VENT PLUG.

Vent Plug The piece or assembly of pieces employed to seal the vent and filling well of a cell cover except for a small hole in the plug itself which permits the escape of gas. Vent plugs are usually held in place either by threads or by a quarter turn catch (bayonet vent plug), or by a snap-in fit.

Vent Well The hole or holes in a cell cover through which gas escapes, fluids are added or the electrolyte level is checked. The vent plug or vent assembly fits into the vent well.

Volt The practical unit of measurement of electro-motive force or potential difference required to send a current of one ampere through a resistance of one ohm.

Voltage The difference of potential which exists between the terminals of a cell or battery, or any two points of an electrical circuit.

Voltage Range The difference between the maximum and minimum cell voltages that exist within a battery or string of cells when all of the cells are charging or discharging.

Voltmeter An instrument for measuring voltage.

Watering Adding water to battery electrolyte to replace electrolysis and evaporative losses.

Notes:



QUALITY SYSTEM
CERTIFIED
ISO 9001
ISO/TS 16949
ENVIRONMENTAL
SYSTEM CERTIFIED
ISO 14001



UL Recognized Component



East Penn Manufacturing Co., Lyon Station, PA 19536-0147
Domestic & International Inquiries Call: 610-682-3263
Phone: 610-682-6361 • Fax: 610-682-0891
www.eastpennunigy.com • e-mail: sales@eastpennunigy.com



Domestic Inquiries Call: 1-800-372-9253
www.mkbattery.com • e-mail: sales@mkbattery.com

All data subject to
change without notice.
No part of this document may
be copied or reproduced,
electronically or mechanically,
without written permission
from the company.